

Forged Steel Industrial Wheels



Forged Steel Industrial Wheels are available in the wide range of standard sizes show below. In addition, wheels to meet your special design requirements can be produced in virtually any size, configuration and surface finish condition. We maintain a large inventory of carbon and alloy steels to meet your specific needs.

Forged Wheels are available in any surface hardness up to 62 RC including our standard heat treatments.

- Untreated, Annealed, Normalized
- Rim Toughened (34-40 RC)
- Deep Hardened (Up to 62 RC)
- Differentially Hardened (Up to 62 RC)
- Super Tough AISI-4140

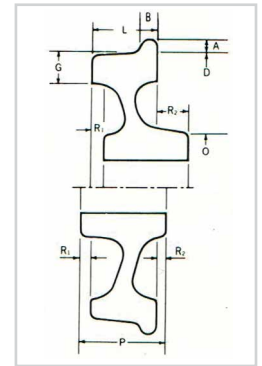
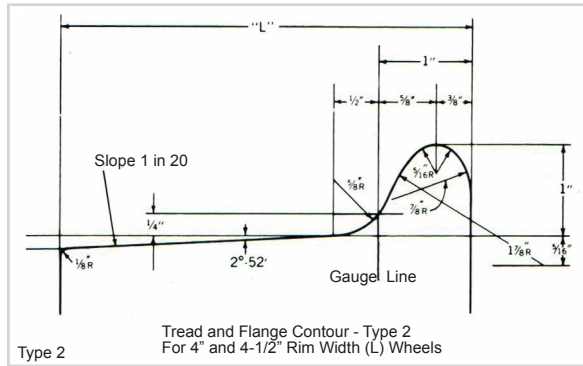
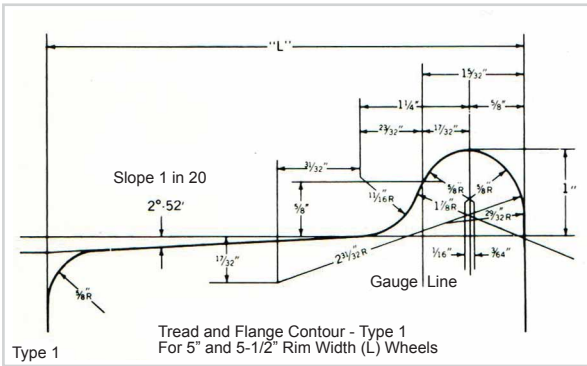

Standard Industrial Wheels Dimensional Data (Inches)

Wheel Section Number*	Nominal Weight, lbs.	Tread Dia. D	Flange Height A	Flange Thickness B	Rim Width L	Rim Thickness G	Hub Diameter O	Hub Length P	Hub Projection	
									Back R ₂	Front R ₁
WIW-122	130	12	1	1	4-1/2	1	5-1/2	6-1/2	1	1
WIW-141	145	14	1	1	4	1	5-1/2	6	1	1
WIW-143	235	14	1	1-5/32	5-1/2	1-1/4	7	7-1/2	1	1
WIW-152	235	15	1	1-5/32	5	1-1/2	7-1/2	7	1	1
WIW-161	175	16	1	1	4	1-1/4	6	6	1	1
WIW-164	305	16	1	1-5/32	5-1/2	1-1/2	9	7-1/2	1	1
WIW-181	230	18	1	1	4	1-1/2	7	6	1	1
WIW-185	360	18	1	1-5/32	5	2	9	8	2	1
WIW-186	385	18	1	1-5/32	5-1/2	2	9	8-1/2	2	1
WIW-202	340	20	1	1-5/32	5	1-1/2	8	7	1	1
WIW-204	525	20	1	1-5/32	5-1/2	1-3/4	12	8	2-1/2	0
WIW-224	440	22	1	1-5/32	5-1/2	1-1/2	9-1/2	7	2-7/16	15/16*
WIW-225	500	22	1	1-5/32	5-1/2	1-1/2	12	7	2-7/16	15/16*
WIW-226	420	22	1	1-5/32	5-1/2	1-1/2	10-1/4 - 10**	5-1/2	0	0
WIW-227	545	22	1	1-5/32	5-1/2	1-1/2	14	6-3/28	1-9/16	11/16*
WIW-243	485	24	1	1-5/32	5	2	9-1/2	6-1/2	2-7/16	15/16*
WIW-244	575	24	1	1-5/32	5-1/2	2-1/2	10	7	2-7/16	15/16*
WIW-245	590	24	1	1-5/32	5-1/2	2-1/2	11	7-1/2	3-3/16	1-3/16*
WIW-246	615	24	1	1-5/32	5-1/2	2-1/2	12	7-1/2	3-3/16	1-3/16*
WIW-247	635	24	1	1-5/32	5-1/2	2-1/2	13	7-1/2	2-3/16	3/16*
WIW-262	510	26	1	1-5/32	5-1/2	1-3/4	8-1/2	5-3/4	1/4	0
WIW-263	630	26	1	1-5/32	5-1/2	2-1/2	10	7	2-7/16	15/16*
WIW-265	635	26	1	1-5/32	5-1/2	1-1/2	14	6-3/8	1-9/16	11/16*
WIW-283	800	28	1	1-5/32	5-1/2	2-1/2	13-1/2	7-1/2	3-3/16	1-3/16*
WIW-302	840	30	1	1-5/32	5-1/2	2-1/2	13-1/2	7-1/2	3-3/16	1-3/16*
WIW-332	1000	33	1	1-5/32	5-1/2	2-1/2	13-1/2	7-1/2	3-3/16	1-3/16*
WIW-362	1150	36	1	1-5/32	5-1/2	2-1/2	13-1/2	7-1/2	3-3/16	1-3/16*

*Denotes front hub depression **Larger dimension is front diameter, smaller dimension is back diameter